

Made for Life

From more to one.

It develops the concept of Minimalism life style to improve human well-being through the technology of high-quality, comfort and sustainability services.

Quality

Feeling of life quality. The appearance keeps simple geometry to bring clean and harmonious feeling. The design gives a reliable in & outdoor lighting tool.



Comfort

Feeling of comfort atmosphere. Color temperature can switch base on different surroundings and visual needs.



Sustainability

We hope to take responsibly to make designs and products and solutions that are efficient, reduce waste and environment friendly.





Product Description

Rechargeable table lamp with a contact charging base. Cordless table lamp providing direct downward and glare-free light. more than 9 hours of battery life. IP65 protection, making it ideal for indoor and outdoor use. Head, rod and base made in corrosion resistant and painted aluminium alloy. Protection with polyester powder coating. Diffuser made in polycarbonate. Product with no visible screws.

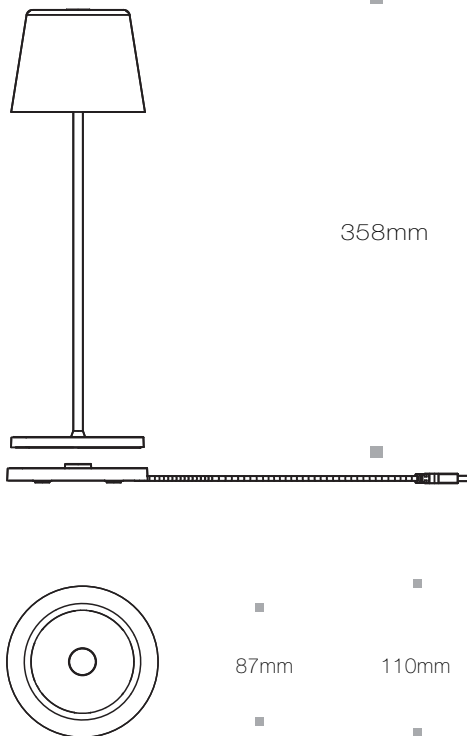

Technical Information

Light source: OSRAM LED Module
Colour temperature: 2700K & 3000K (switchable)
Colour rendering index: CRI > 80
Luminaire connected wattage: 2.2 W
Voltage: DC3.7V
Luminaire luminous flux: 150 lm
Light optics: 100°
Light distribution: Wide
Battery type: 18650 Li-ion battery
Battery capacity: 2200mA×2
Battery charge: <6hrs
Battery life: >9hrs (100% light intensity)
Battery charge protection: Equipped with a self-protection system
Adapter(optional): CLASS II; Input AC100-240V; Output DC5V 1A;
Single contact charging base incl-: 1.5m USB cable
Multi contact charging shelf(optional): Stackable up to 3 levels. One charger shelf charges 6 table lamps together.
Switch: Touch ON/OFF
Dimmer: Touch stepless dimmable 5%-100%
Memory function: Memory of brightness
Protection class: IP65
Safety: Class III
Weight: 0.85kg

Finish Available

Dark Grey		Matt White		Orange		Blue	
Matt Black		Corten		Green Grey		Yellow	





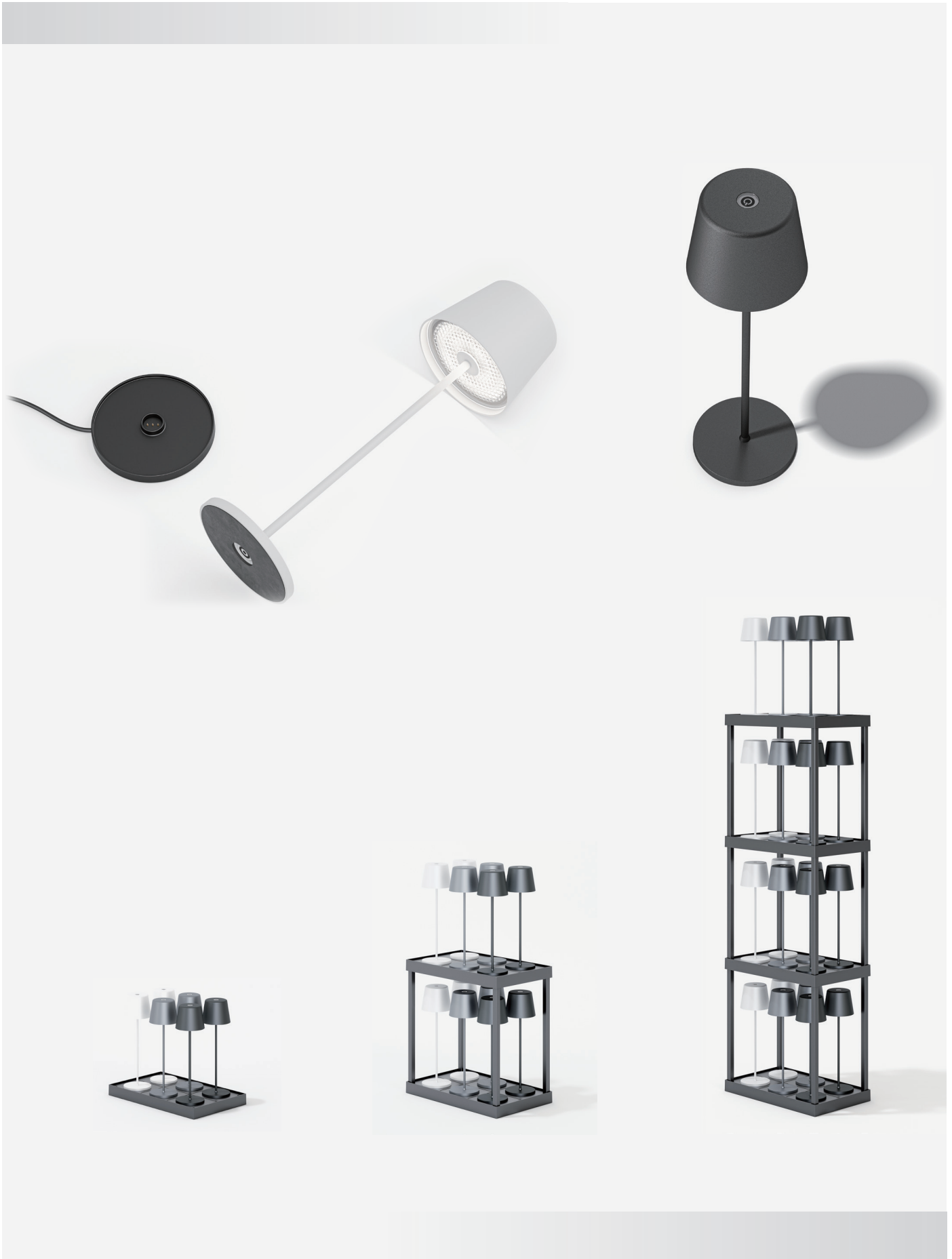



Accessories

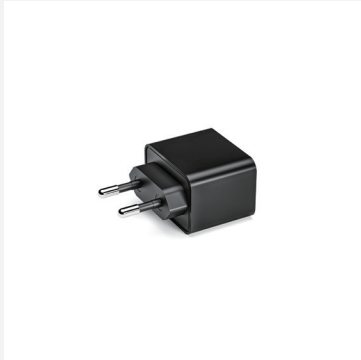

Item No.: A0202

Description: USB Adapter, CLASS II, Input AC100-240V, Output DC5V 1A



Item No.: A0201

Description: Multi contact charging shelf. Stackable up to 3 levels. One chargershelf charges 6 table lamps together.



Item No.: A0203

Description: Table lamp round shape single charger (contact charging base).